

# GERGEN CITY SKIP LOADER



**GERGEN**   
Kipper- und Fahrzeugbau

## A FOCUS ON THE FUTURE FOR GENERATIONS

For more than 85 years we have been developing transport and disposal solutions for your success! The skip loaders from GERGEN set the standards. All outstanding developments of the last decades have been created at our location in Saarland, Germany.

GERGEN builds city skip loaders of the best quality, constantly adapted to the new market requirements and equipped with outstanding details.

This is what makes GERGEN's city skip loaders so unique.



Leo Gergen  
1907-1980



Hans-Georg, Ottmar and  
Engelbert Gergen  
1967-2013



Arndt Kreutzer  
Executive Partner  
since 2013

CHALLENGE US

WE PROVE WHAT WE CAN DO

WE EMBRACE PROGRESS

**GERGEN**   
Kipper- und Fahrzeugbau

# THE NEW SERIES

The city skip loader combines the advantages of GERGEN products that have been tried and tested since the 1950s with a very low tare and weight and a high payload.

We have always aimed to incorporate the practical experience of our customers into the development process of our vehicles. This is achieved through a constant exchange of ideas between the operators, their drivers and our design team.

GERGEN city skip loaders arouse emotions with their modern design and perfectly shaped basic structure.

# CITY SKIP LOADER

**OUR SMALL ONES ARE LOOKING FORWARD TO WORK WITH...**

- Disposal companies
- Construction companies
- Gardening and landscaping
- Roofing companies
- Municipal companies
- Craft businesses

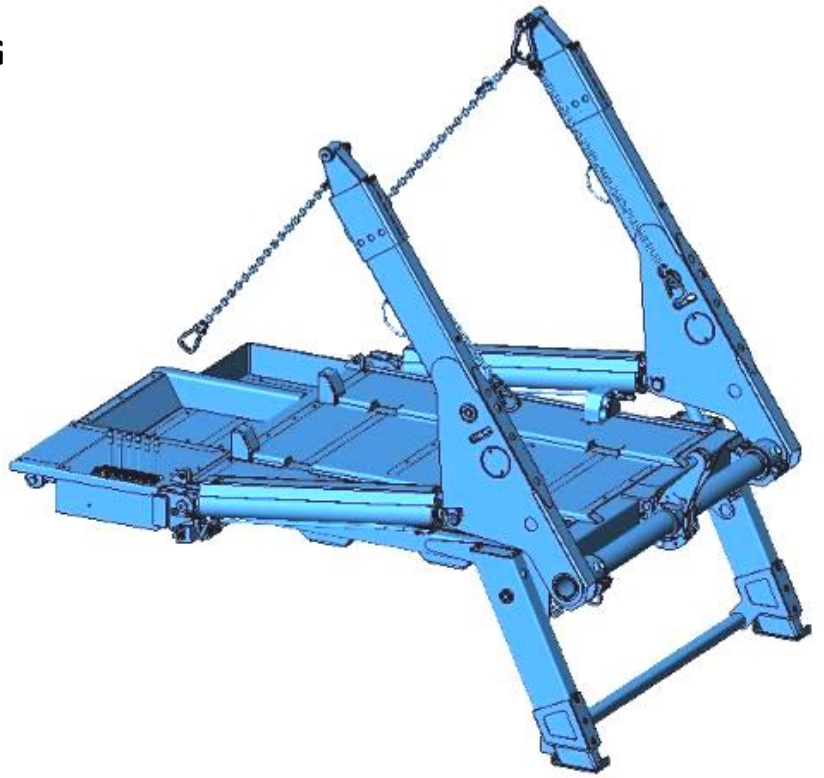

TAK 4 Adonis



TAK 4 SW

# TECHNICAL DATA

MODELS:	TAK 4, TAK 6, TAK 8 (+ TAK 6 AX and SW)
TOTAL WEIGHT:	3,5 to 14 t
TECHNICAL LIFTING CAPACITIES:	2,5 to 7,5 t
WEIGHT OF CONSTRUCTION:	800 to 2.000 kg
RECOMMENDED WHEELBASE:	2.500 to 3.700 mm
CONTAINER SIZES:	2,0 to 10 m <sup>3</sup> (DIN 30720 + DIN 30735)

## Durability of the corrosion protection

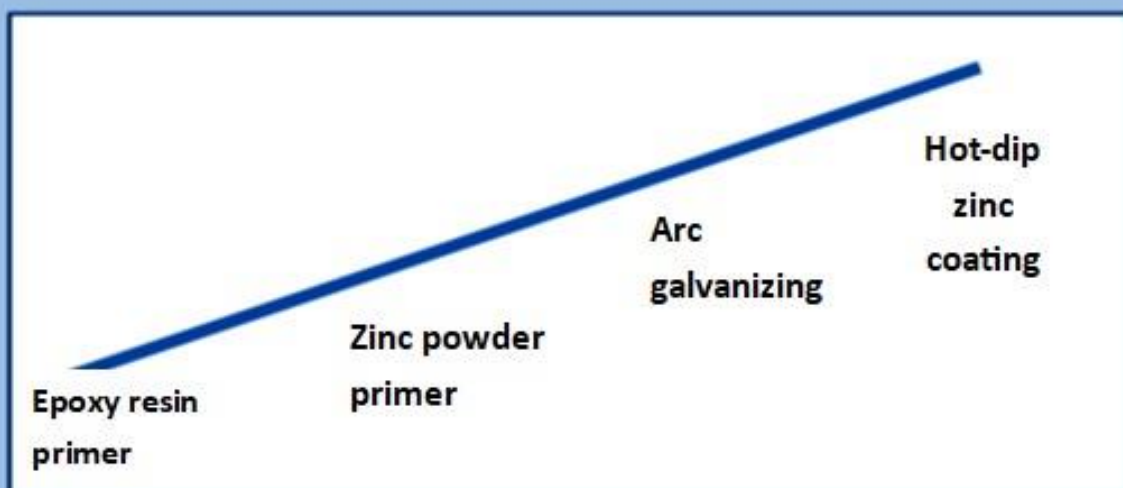

# TAK 4 - 6 - 8



TAK 6 AX Adonis

**GERGER**   
Kipper- und Fahrzeugbau

# ADONIS CITY SERIES

## THE NEW GERGEN CITY SKIP LOADER

The first generation of the telescopic skip loader with gooseneck was a pioneering development.

A lighter body with a low overall height for use with various container sizes and with tipping function.

Regardless of whether you are doing heavy-duty work or want to go „up high" - we have the "tailor-made suit" for you!



TAK 4 Adonis

# TYPICALLY GERGEN...

**1. HYDRAULIC CONTAINER LOCKING, 2-fold (optional)**

**2. CORROSION PROTECTION of the entire construction (optional)**

**3. STORAGE TRAY:** an individually adaptable, floor-level storage tray is fitted in front of the loading bridge as standard, allowing optimum use of space.

Storage box in various designs (optional)

Also available with a lid or as a high aluminum stacking box on request.

**4. PREMIUM STORAGE BOXES from Gepro-BOX (optional)**



# MANY PRACTICAL IDEAS FOR PRECISE AND EFFICIENT WORK!

5. Accessible and LOW-MAINTENANCE COMPONENTS

6. 3-FOLD TILTING HOOK SYSTEM: middle hook can be controlled separately (optional)

The tilting hooks are mounted on the rotating shaft with two half shells.  
This makes it possible to quickly expand from the 1 to the 3 hook system.



# TAK 6 ADONIS

**7. SUPPORT LEGS:** separately controllable, hot-dip-zinc-coated

Optional: Roller or pendulum plates. Support plates incl. hot-dip zinc-coated plate holders, as accessories.

**8. CYLINDER PROTECTION COVER AND LIGHTING SUPPORT** made of aluminum checker plate.

**9. SEPARATELY CONTROLLABLE TELESCOPIC ARMS** offer maximum flexibility even in the smallest of spaces. This allows you to position the container precisely without the need for tiresome reparking.



# INNOVATIONS THAT PAY OFF!

## 10. HOT-DIP ZINC-COATED ACTIVE LOAD SECURING



11.

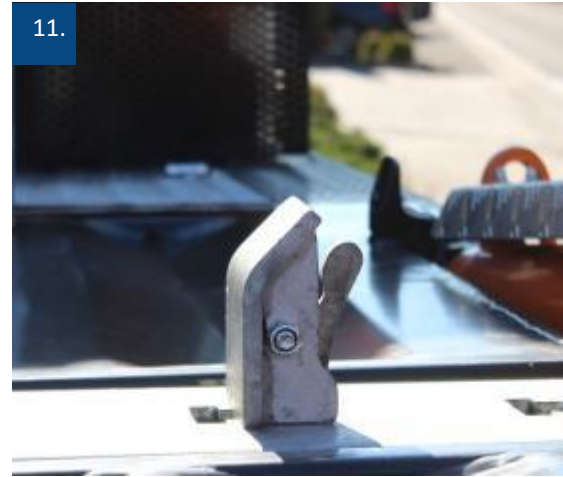

**11. REINFORCED KEY PLATE:** with hot-dip zinc-coated guides with variable stop. These adapt effortlessly to different container shapes. Optional: securing eyes for safe lashing.

**12. The HOT-DIP ZINC-COATED 2-FOLD HYDRAULIC CONTAINER LOCKING SYSTEM** enables containers of different sizes and waste compactors to be transported safely in accordance with the latest VDI guidelines using extended telescopes. Additional tensioning of the chains is not necessary.



12.

# TAK 6 AX ADONIS WITH EXTENDABLE MAIN ARMS



## NOT AFRAID OF BIG JOBS!

For use with containers in accordance with DIN 30735 from 2-5,0 m<sup>3</sup> and in accordance with DIN 30720 Part 1 up to 7 m<sup>3</sup>

We offer you the **advantages** of our large skip loader series, even with our **smaller** models:

- Containers with 10 m<sup>3</sup> can be transported depending on the wheelbase, **but** can only be tilted to a limited extent (mini containers on request).

**EXTENDABLE** from 1.740 mm to up to 2.040 mm internal width

- Single or 3-fold tilting hook
- Highly used attachments are hot-dip zinc coated as standard
- Maintenance openings for reduced maintenance effort

**Many other attachments and accessories are available for all TAK Adonis series.**



TAK 6 AX: extended arms



TAK 6 AX: retracted arms

# HELIOS 8

DIN 30720 containers up to 10 m<sup>3</sup> can be loaded (due to the **horizontal movement** of the arms).

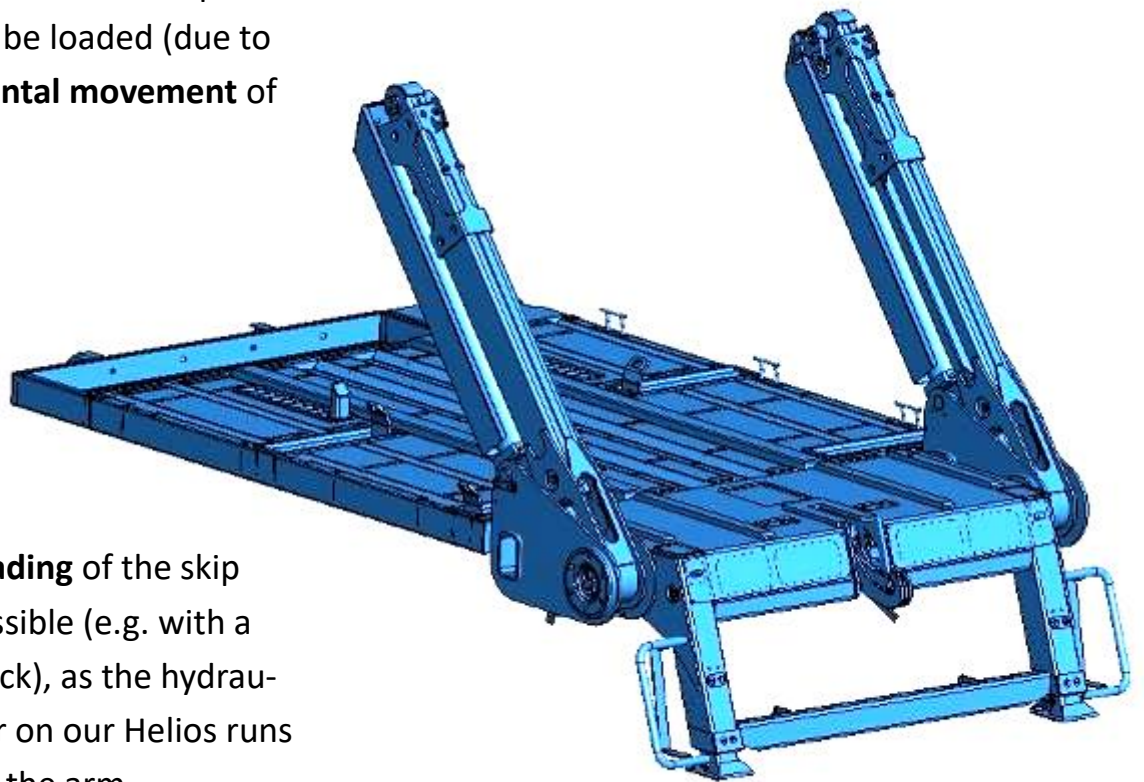

**Lateral loading** of the skip loader possible (e.g. with a forklift truck), as the hydraulic cylinder on our Helios runs parallel to the arm.



Helios 8 standard



Helios with side wall



Helios with loading crane



Helios with high storage box

# TAK 4 SW

ROTATABLE STRUCTURE

FLEXIBLE

LIGHTWEIGHT

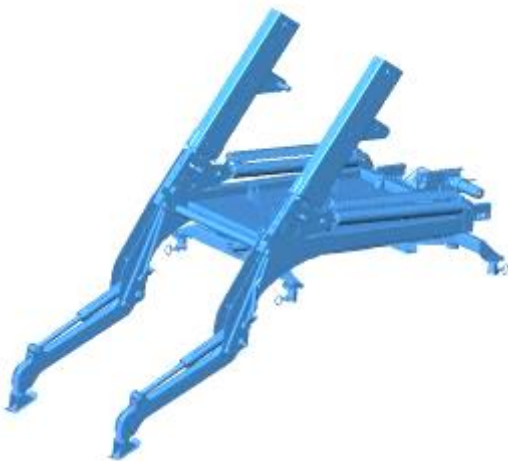

Our city skip loader TAK 4 SW, **which can be rotated in both directions**, is particularly suitable for depositing containers in areas where is not much space available, e.g. in cemeteries and city centers.

Thanks to the **swivel function** of the entire construction by **90°** in both directions, it is not only possible to load and unload containers from the rear, but **also from the side**.

This means significantly **more flexibility** in your daily work!

The safe position of the vehicle is ensured by the projecting supports.

# UNLIMITED POSSIBILITIES



**GERGER**   
Kipper- und Fahrzeugbau

# THE GERGEN CONTROL SYSTEM

The GERGEN control units impress with simple operation and provide unrestricted mobility when operating the vehicle.

Changing requirements call for modern and innovative products...

... WE ARE PREPARED FOR THE FUTURE!

# RADIO CONTROL SYSTEMS



Zusätzliche Außensteuerung serienmäßig



**GERGEN**   
Kipper- und Fahrzeugbau

## GERGEN Kipper- und Fahrzeugbau GmbH

Geistkircher Str. 14

66386 St. Ingbert

**Tel:** +49 (0) 6894 9203-0

**Fax:** +49 (0) 6894 9203-119

**Mail:** [welcome@gergen-kipper.de](mailto:welcome@gergen-kipper.de)

**Web:** [www.gergen-kipper.de](http://www.gergen-kipper.de)

Folgen Sie uns auch auf:



**GERGEN**   
Kipper- und Fahrzeugbau